

User -and installation manual

Warning! Before proceeding with installation, read the recommendation and suggestion in the user manual.

Luna

Wall



Before starting the installation, please check the product for transportation damages. All queries regarding installation and product info, please contact www.roroshetta.uk or tel. +47 72 40 94 00, or E-Mail: support@roroshetta.no

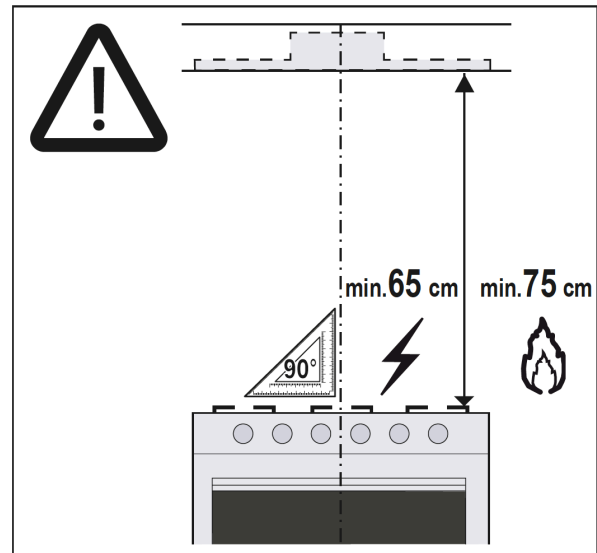
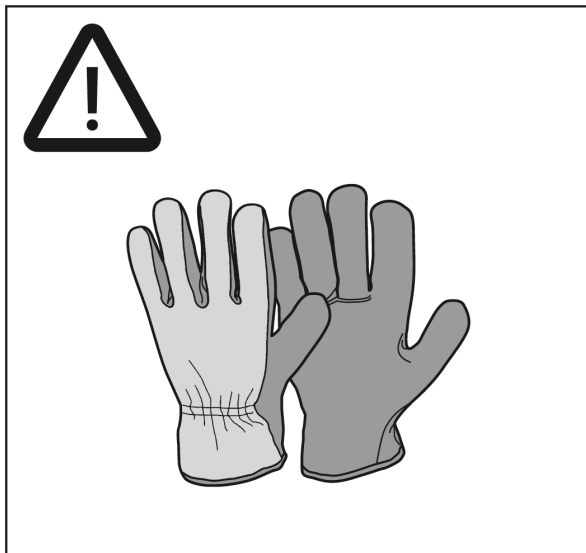

RørrosHetta Luna 60 X 57,6

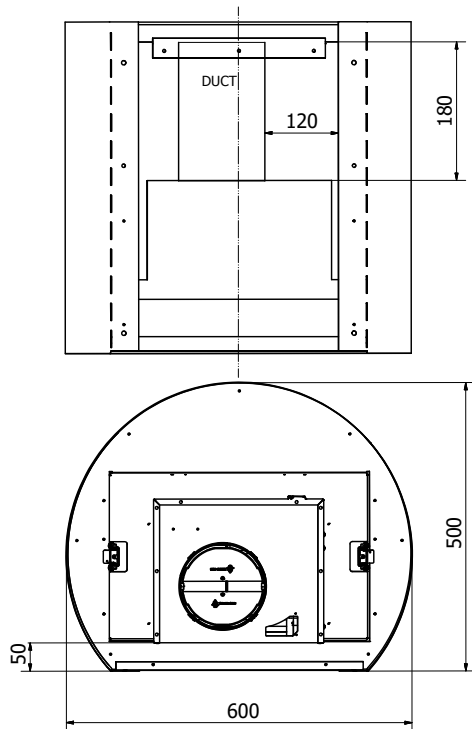

Fig. 1

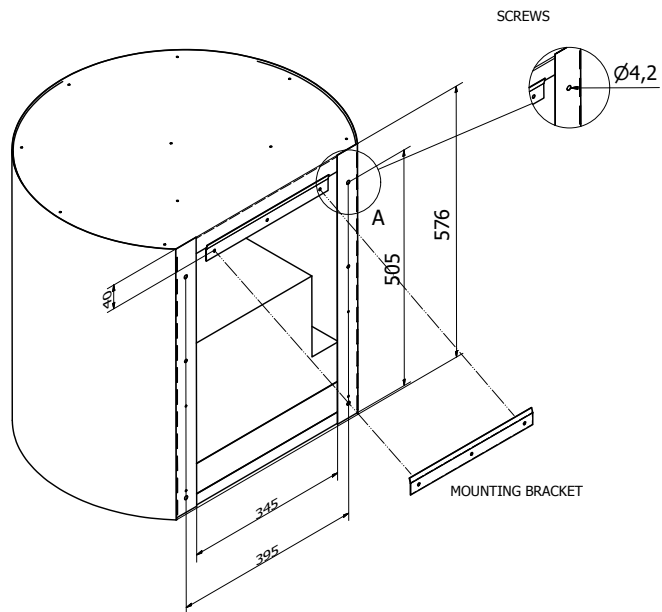

Fig. 2

Hood installation height

The distance above gas stoves must be min. 75 cm. This is due to the fire hazard. Otherwise, it is recommended between 65-75 cm, depending on the model and the height of the individuals living in the household. The lower the hood is above the cooktop, the more efficient the capturing of cooking odours, grease and smoke.

Assembly instruction

Step 1:

Determine where the hood is to be mounted.

Step 2:

Use the attached mounting bracket in center, and 40mm below the top of the hood (See Figure 2).

Step 3:

Make the necessary preparation for assembly of the ventilation duct.

Step 4:

Mount the hood on the bracket and fix the additional screws (See figure 2).

Step 5:

Connect the duct to the built-in unit with a hose clamp, **before** installing it into the hood. (Fig. 3)

Step 6:

Install the built-in unit into the hood. Be **careful** not to make any scratches in the bottom plate. See separate user -and installation manual for built-in unit. Charcoal filter (option) is not delivered with the hood, and if necessarily needs to be ordered separately. (Article number RM 9340). See built-in unit manual for installation of charcoal filter.



Scan the QR-Code for installation video

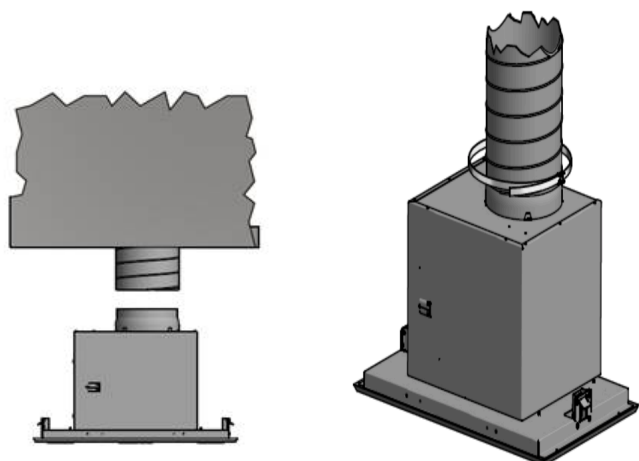

Fig. 3

1. GENERAL INFORMATION

- Please read these operating instructions carefully. They contain information about installation, operation, safety and maintenance you need to take into consideration.
- Check the condition of the hood and the installation material before installing. Carefully remove the hood from the packaging. Be careful not to use sharp knives to open the box.
- Please keep these instructions to pass on to future users.
- Disposal of transport packaging and old appliance. Your new appliance has been sent to you in protective packaging. All utilized materials are environmentally safe and recyclable. Please help us by disposing the packaging in an environmentally friendly manner.
- Old appliances have valuable raw materials which can be reclaimed by recycling old appliances. This appliance is identified according to the European Directive 2002/96/EC on waste electrical and electronic equipment. Please ask your dealer or inquire at your local authority about current means of disposal.

2. SAFETY

2.1 Precautions before using

- Do not change or alter the appliance.
- The appliance must be grounded and connected according to local standards.
- Do not use any extension cable to connect it.

2.2 Using the appliance

- When using the hood, there must always be a sufficient, continuous supply of fresh air in the room. Fresh air can be supplied by opening a window or outside door slightly, or by installing an inlet grille. No matter how big the kitchen or the space with the open kitchen, the amount of air that can be extracted is limited by the amount of air that can be fed into it. An insufficient air supply can result in a 50% loss of efficiency or more.

An extractor fan is usually not a major energy consumer. However, an unnecessarily powerful motor will create a negative pressure in the room that must be replenished with outside air. This replacement air must be heated to room temperature. This requires energy. The

important thing is to find the right balance between effective ventilation and sensible energy consumption.

An insufficient air supply can also cause repercussions in other existing exhaust channels, such as the flue of a fireplace or other combustion appliances. This causes a risk of poisonous and combustible gases being drawn back into the living space. When using the same energy source, other than electricity, for the hood and devices, the negative pressure in the room must not exceed 4 Pa (= 0.04 mbar). Under no circumstances is it allowed to flambé under the hood.

- Deep frying under the hood is only allowed under constant supervision.
- In case of fire always switch off the hood.
- Never extinguish burning fat or oil with water. Cover the pot with a well-fitting lid or a burnblanket.
- This appliance can be used by children aged from 8 years and above and persons with reduced physical, sensory or mental capabilities or lack of experience and knowledge if they have been given supervision or instruction concerning use of the appliance in a safe way and understand the hazards involved.
- Activate the hood a few minutes prior to cooking.
- Switch the hood off 15 minutes after cooking is finished
- Avoid drafts under the hood surface.
- When cooking make sure pots are positioned properly under the hood surface.
- When using induction: adapt the intensity of both hob and hood to the lowest possible level in order to avoid excessive creation of damp fumes.
- **Attention**, certain accessible parts of the hood can become hot while cooking.

2.3 Precautions not to damage the appliance

- The mounting instructions describe the correct way of mounting. Carefully read these instructions.
- Check the distance between the cooking surface and the hood. The minimum and maximum heights are indicated in the mounting instructions.
- Never use the hood without the grease filters in order to prevent dirt and grease from further entering the hood, which will eventually affect the performance and functioning of the hood.
- Always stay close when you are frying, roasting, grilling or deep-frying. Overheated oil and fat may- catch fire and damage the hood and surroundings.

2.4 Pressure loss

The dimension, length and number of bends in the exhaust duct are crucial to how much of the motor's capacity you actually utilize. By using a diameter of 6" (inches) diameter = 150 mm, you will better utilize its capacity. Use ducts that provides minimum resistance. Avoid bends and use a ventilation grid with little pressure loss on the outer wall.

3. Cleaning and maintenance

Painted hoods are easily cleaned using warm water and dish soap. The same applies to brushed metallic hoods.

For stainless steel hoods we recommend steel cleaners, or you can clean them using a damp and then a dry microfiber cloth.

Never use abrasives on high gloss PVD, but instead use e.g. glass cleaner with a paper cloth.

The grease filter should be washed regularly each month. All grease filters may be washed in the dishwasher. Many filters are made of aluminum and can therefore get discolored from dishwasher powders. This does not affect its functionality. See instruction manual for built in unit.

Non-washable charcoal filters should normally be replaced every year. See instruction manual for built in unit.

Absorption

Absorption is the fan's ability to sort and capture fumes. All our extractors capture between 90-99% with a perfect installation. A cooker hood with good absorption capacity does not require such a large amount of air to create a good indoor climate. Several of our models have a volume section at the bottom, which helps to capture fumes even at small air volumes.

Brushless motor – energy efficient and super-quiet

Reducing energy consumption is very important. In our new brushless motor, a new technology provides a more stable motor speed, which in turn leads to a significantly reduced noise level. A brushless motor guarantees significant energy savings combined with high recovery power: -85% power consumption (kW / hr) at medium-low speeds and -35% consumption (kW / hr) at high speeds.

LED lights

LED is short for Light Emitting Diode. LED lamps require very little power and have excellent resistance to impacts and shaking. The LED light bulbs have a pleasant brightness of approx. 4000 K, and an energy consumption of 3 W. All our cooker hoods are being delivered with LED.

4. Technical problem

In case of technical problems please contact RørosHetta at

- Tel.: 00 47 72 40 94 00 or www.roroshetta.uk

Proudly designed and produced in Norway by:



Stamphusveien 11
NORWAY 7374
RØROS
+47 72 40 94 00